



## Comet S6 I

CNC machining centres



4-axis CNC machining centre designed for working bars or parts in aluminium, PVC, light alloys in general and steel. It is equipped with two operating modes: a single work area for bars up to 7 m length or two independent work areas in double mode. The machine is equipped with independent motorized vices that allow positioning the vices in concurrent operation time during the operation in dynamic pendular mode. The 4th NC axis allows the electrospindle to rotate from  $-120^{\circ}$  to  $+120^{\circ}$  on the horizontal axis and position itself at any intermediate angle. The machine can therefore perform machining operations on the top and on all side faces of the profile at any angle within the range. It is equipped with a 12-place tool magazine, on the X axis gantry, able to host also one milling disc. It also has a mobile work table that facilitates the workpiece loading/unloading operation and significantly increases the workable section.



**4 axes electric head -S-**

The 8.5 kW electrospindle in S1 with high torque also enables performing the heavy machining typical of the industrial sector. A 10.5 kW electrospindle with encoder for rigid tapping is available as optional. Electrospindle rotation along A axis allows working on 3 sides of the profile, with no need of repositioning.



**Operator interface**

The possibility of rotating the monitor on its vertical axis allows the operator to view the screen from any position. The user interface has a 24" touchscreen display in 16:9 format, portrait mode, equipped with the necessary USB connections for PC and CNC remote interfaces. It also features an operator panel, mouse, and it is set up for connecting barcode reader and remote operator panel.

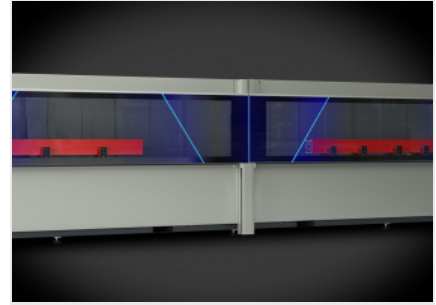

**Dynamic double operation**

The innovative machining mode allows minimising downtimes when loading and unloading the workpieces to be machined. The system allows, in the two distinct and independent work areas, to simultaneously carry out the loading/unloading of extruded profiles on one side, and machining of workpieces on the other, with different lengths and/or codes.

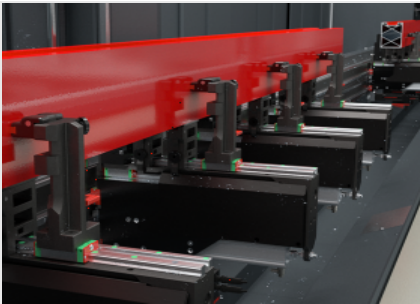

**Motorized vices**

The motorized vices, each equipped with its own motor, can be positioned independently in the work area. The CNC manages the movement of vices and that of electrospindle head simultaneously, in the two different work areas in double operation mode. This enables significant productivity gains. Using absolute reference axes allows reducing the initialisation time required every time the machine is restarted.



**Tool magazine**

The tool magazine is integrated on the X axis, in the lower part and behind the electrospindle. It allows great reduction of tool change times. This function is particularly useful in the extrusion head and tail machining, avoiding the stroke to get to the magazine, as it moves simultaneously with the electrospindle and its positions.

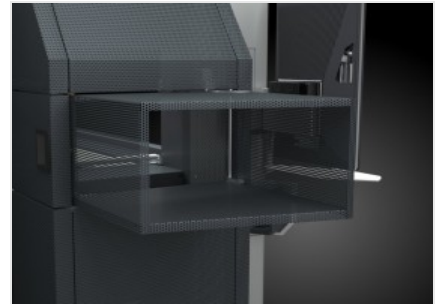

**Foldaway tunnel (Optional)**

Integrated with the machine's aesthetics and design, thanks to the perforated sheet metal for transparency and lightness, the tunnel opens and closes as needed. As its length can be reduced when not in use, it helps save space at the workshop. The outlet for the chip conveyor belt and its engine are built into the lower section, in view of an aesthetic and functional design.



**Emmegi S.p.A.**  
Via Archimede, 10  
41019 - Limidi di Soliera (MO)  
ITALY

Tel +39 059 895411  
Fax +39 059 566286  
P.Iva/C.Fisc 01978870366  
info@emmegi.com  
www.emmegi.com

The right to make technical alterations is reserved.



**COMET S6 I / CNC MACHINING CENTRES**

**LAYOUT**

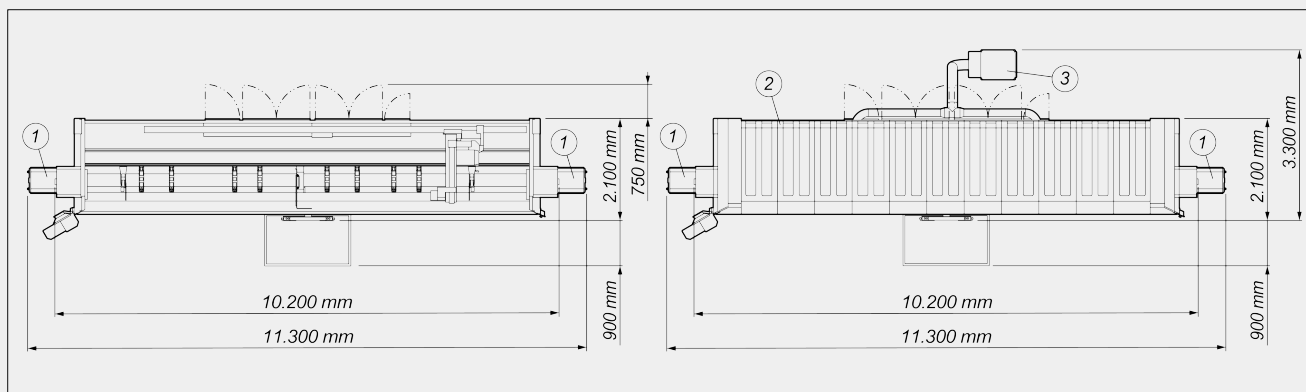

Machine height (maximum Z-axis extension) (mm) 2.590

Machine height with top cover (mm) 2.710

- 1. Chip conveyor and swarf drawer (optional)
- 2. Cabin enclosure (optional)
- 3. Fume extraction system (optional)

The overall dimensions may vary depending on the product configuration.

**AXIS STROKES**

X AXIS (longitudinal) (mm) 7.340

Z AXIS (vertical) (mm) 450

Y AXIS (transversal) (mm) 1.000

A AXIS (rotation on electrospindle horizontal axis) -120° ÷ +120°

**ELECTROSPINDLE**

Maximum power in S1 (kW) 8,5

Maximum power in S6 (60%) (kW) 10

Maximum speed (rpm) 24.000

Toolholder cone HSK - 63F

Automatic tool holder coupling ●

Cooling with heat exchanger ●

Electrospindle controlled on 4 axes with the possibility of simultaneous interpolation ●



**WORK AREA**

1F = 1 face machining

5F = 5 faces machining

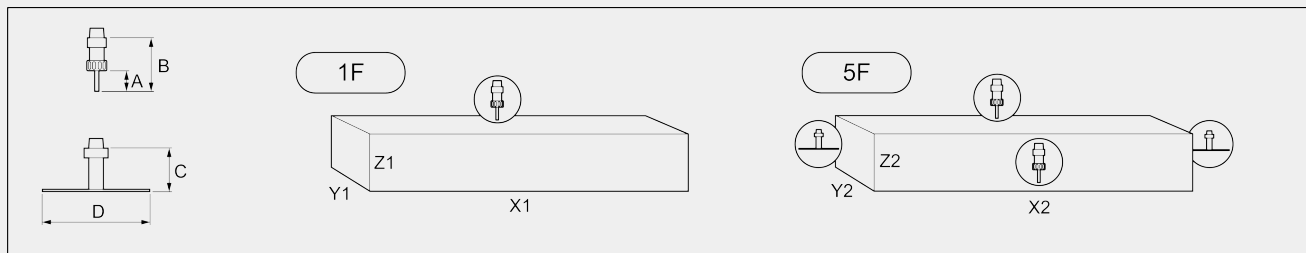

		A	B	C	D	X1	Y1	Z1	X2	Y2	Z2	
<b>COMET S6 I</b>	single mode	60	130	95	250	6.880	300	210	6.880	250	215	
	asymmetrical double mode	lh	60	130	95	250	3.250	300	210	3.120	250	215
	asymmetrical double mode	rh	60	130	95	250	2.785	300	210	2.650	250	215
	symmetrical double mode	lh	60	130	95	250	2.970	300	210	2.840	250	215
	symmetrical double mode	rh	60	130	95	250	3.065	300	210	2.930	250	215

Dimensions in mm

**TAPPING CAPACITY (with Tap On Aluminium And Through Hole)**

With compensator	M8
Stiff (optional)	M10

**WORKPIECE LOCKING**

Standard number of pneumatic vices	8
Independent motorised vices	●
Maximum number of pneumatic vices	12
Maximum number of vices per area	6

**AUTOMATIC TOOL MAGAZINE ON BOARD THE GANTRY**

Maximum number of magazine tools	12
Maximum diameter of the blade that can be inserted in the magazine (mm)	Ø = 250

**FUNCTIONS**

Multi-piece operation	<input checked="" type="radio"/>
Basic multi-step machining - up to 5 steps	<input checked="" type="radio"/>
Dynamic double operation	<input checked="" type="radio"/>
Automatic management of multi-step mode machining	<input type="radio"/>
Workpiece rotation for machining on 4 sides	<input type="radio"/>
Extended machining, up to twice the maximum nominal length in X	<input type="radio"/>
Multi-piece mode machining in Y	<input type="radio"/>

Included ● Available ○