



ACCA XL

Manual assembly benches



The bench is suitable for any fitting and assembly operation of door and window frames. The sliding and extendable tops allow operations with every size frames and very big structures in complete safety.



Adjustable feet

Height adjustable feet to ensure the work bench can be positioned at the required height and perfectly flush with the other products in the Dynamic Line. The feet also have holes so they can be anchored to the floor.

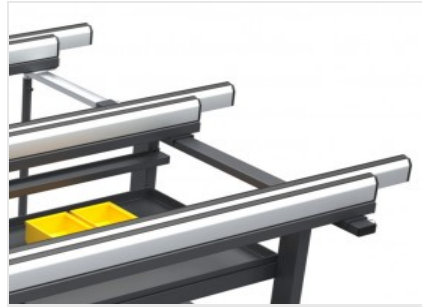

Surface in nonslip PVC

The working surfaces are covered with soft nonslip PVC that provides secure support when positioning the frame.



Drawers

A series of convenient bins allow for the storage of small parts in a simple and orderly manner for easy identification of items.



Pneumatic system

Quick-connect taps that ensure compressed air supply with ease.



Extendible support surface

Adaptation to any size of frame is ensured by the presence of both horizontally sliding table tops and the extendible support that slides on wheels, allowing for a very flexible increase in the size of the work bench.





ACCA XL / MANUAL ASSEMBLY BENCHES

CHARACTERISTICS

Benches for laying tools and accessories	2
Small parts containers	6
Soft PVC contact surface	●
Height adjustable work bench	●
Pneumatic system with 2 quick-connect taps	●
Feet with holes for ground fixing	●
Sliding and width-adjustable supporting tables	●
Sliding and length-adjustable supporting table	●
Length (mm)	1.330 ÷ 2.440
Width (mm)	2.180 ÷ 4.000
Height (mm)	875 ÷ 1.000
Load capacity (kg)	250

Included ● Available ○