



Comet R6 HP

CNC machining centres



5-axis CNC machining centre used for the working of bars or aluminium, PVC, light alloys in general and steel pieces. It is provided with two operating modes: a single work area for bars up to 7 m length or two independent work areas in swing mode. The machine in HP version is equipped with 2 additional axes for positioning of vices and reference stops, that allow positioning the vices while the machine is working in swing mode. The 4th and 5th axis allow the electric spindle to continuously rotate to NC from -15° to 90° on horizontal axis and from 0° to 720° on continuous vertical axis, to perform the work on the upper side and on all the lateral sides of the profile. It is provided with a 12-place tools magazine, on the X axis gantry, able to host also one milling disc. It also has a mobile work surface that facilitates the piece loading/unloading operation and significantly increases the workable section.

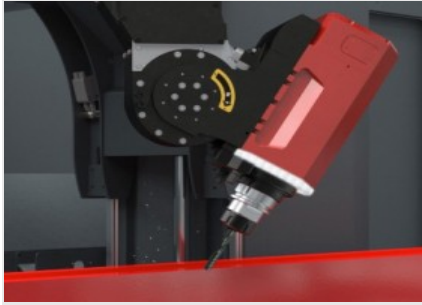

5 axes electric head -R-

8.5 kW S1 high torque electrospindle also allows heavy duty machining, which is typical in industrial processing. As an option and for higher performances a 11 kW encoder equipped electrospindle is available for rigid tapping. Electrospindle rotation along B and C axes allows working on 5 sides of the profile, with no need of repositioning.

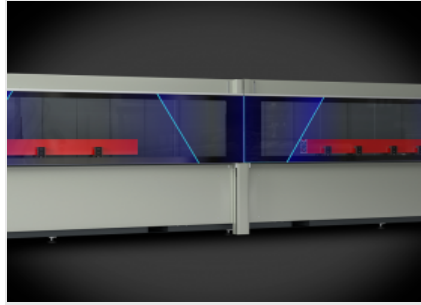

Dynamic double operation

The innovative machining mode allows minimising downtimes when loading and unloading the workpieces to be machined. The system allows, in the two distinct and independent work areas, to simultaneously carry out the loading/unloading of extruded profiles on one side, and machining of workpieces on the other, with different lengths and/or codes.



HP version

Comet has two operation modes: a single work area for bars up to 7 m long, or two independent work areas in double operation mode. The machine in HP version is equipped with 2 additional axes for positioning of vices and reference stops, that allow positioning the vices while the machine is working in double mode.

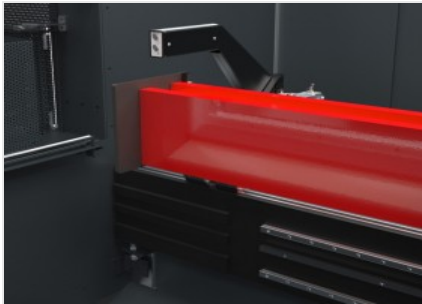

Vice positioner

Vice unit positioning is performed by two numerically controlled axes, H and P, parallel to the X-axis, with on-board reference stop. This solution allows positioning stops all along the machine to work in multi-workpiece mode with one profile for every pair of vices. Furthermore, the positioning of the vices takes place independently of the operational condition of the spindle (X-axis).



Operator interface

The possibility of rotating the monitor on its vertical axis allows the operator to view the screen from any position. The user interface has a 24" touchscreen display in 16:9 format, portrait mode, equipped with the necessary USB connections for PC and CNC remote interfaces. It also features an operator panel, mouse, and it is set up for connecting barcode reader and remote operator panel.



Tool magazine

The tool magazine is integrated on the X axis, in the lower part and behind the electrospindle. It allows great reduction of tool change times. This function is particularly useful in the extrusion head and tail machining, avoiding the stroke to get to the magazine, as it moves simultaneously with the electrospindle and its positions.





COMET R6 HP / CNC MACHINING CENTRES

LAYOUT

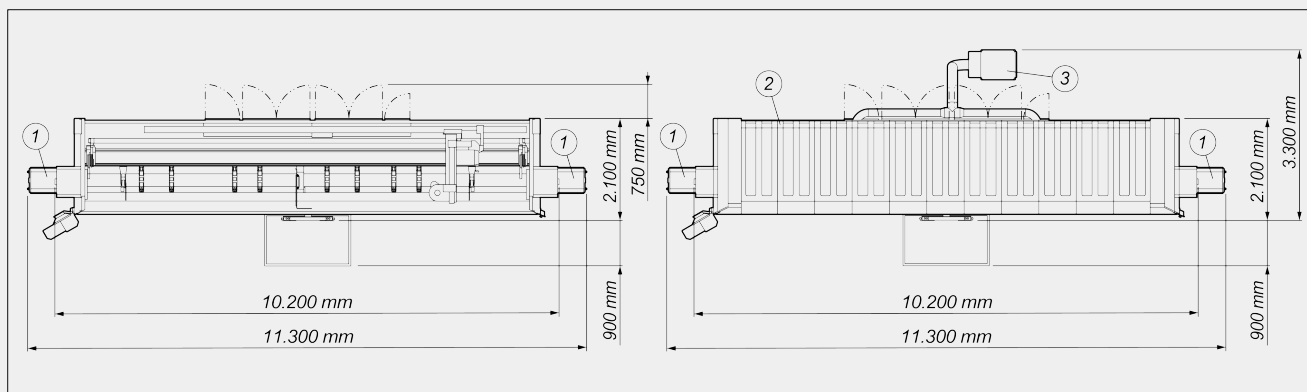

Machine height (maximum Z-axis extension) (mm) 2.590

Machine height with top cover (mm) 2.710

- 1. Chip conveyor and swarf drawer (optional)
- 2. Cabin enclosure (optional)
- 3. Fume extraction system (optional)

The overall dimensions may vary depending on the product configuration.

AXIS STROKES

X AXIS (longitudinal) (mm) 7.660

Y AXIS (transversal) (mm) 1.000

Z AXIS (vertical) (mm) 450

B AXIS (rotation on electrospindle horizontal axis) $-15^{\circ} \div +90^{\circ}$

C AXIS (rotation on electrospindle vertical axis) $-360^{\circ} \div +360^{\circ}$

ELECTROSPINDLE

Maximum power in S1 (kW) 8,5

Maximum power in S6 (60%) (kW) 10

Maximum speed (rpm) 24.000

Toolholder cone HSK - 63F

Automatic tool holder coupling ●

Cooling with heat exchanger ●

Electrospindle controlled on 5 axes with the possibility of simultaneous interpolation ●



WORK AREA

1F = 1 face machining

5F = 5 faces machining

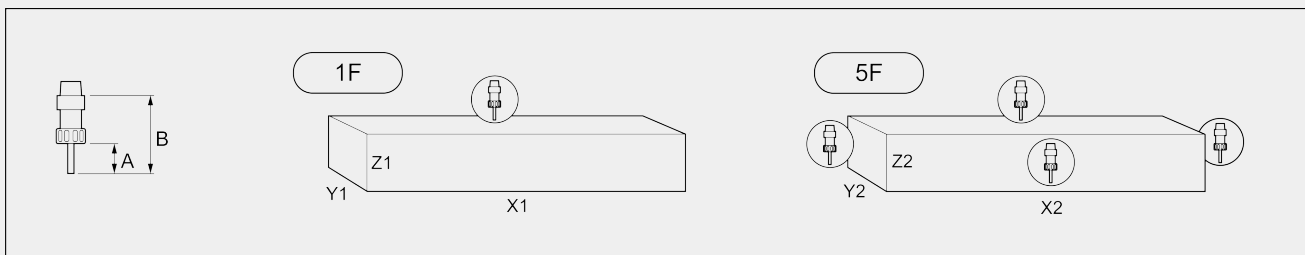

COMET R6 HP		A	B	X1	Y1	Z1	X2	Y2	Z2
single mode		60	130	7.070	300	250	6.785	250	250
asymmetrical double mode	lh	60	130	3.315	300	250	3.030	250	250
asymmetrical double mode	rh	60	130	2.660	300	250	2.470	250	250
symmetrical double mode	lh	60	130	3.035	300	250	2.750	250	250
symmetrical double mode	rh	60	130	2.940	300	250	2.750	250	250

Dimensions in mm

TAPPING CAPACITY (with Tap On Aluminium And Through Hole)

With compensator	M8
Stiff (optional)	M10

WORKPIECE LOCKING

Standard number of pneumatic vices	8
Maximum number of pneumatic vices	12
Automatic vice positioning and workpiece reference stops through independent H and P axes	●
Maximum number of vices per area	6



AUTOMATIC TOOL MAGAZINE ON BOARD THE GANTRY

Maximum number of magazine tools	12
Maximum diameter of the blade that can be inserted in the magazine (mm)	Ø = 250

FUNCTIONS

Multi-piece operation	<input checked="" type="radio"/>
Extended machining, up to twice the maximum nominal length in X	<input type="radio"/>
Dynamic double operation	<input checked="" type="radio"/>
Basic multi-step machining - up to 5 steps	<input checked="" type="radio"/>
Multi-piece mode machining in Y	<input type="radio"/>
Automatic management of multi-step mode machining	<input type="radio"/>
Workpiece rotation for machining on 4 sides	<input type="radio"/>

Included ● Available ○