

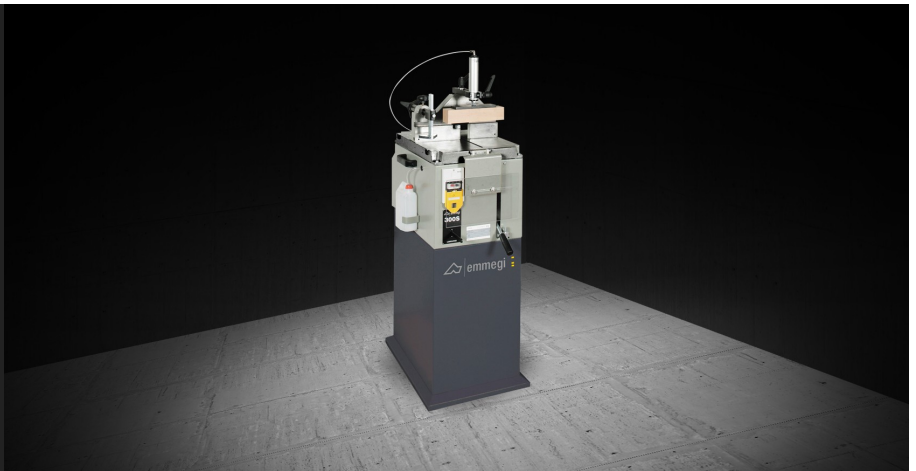

M-S 300

Single head cutting-off machines



Single-head, rising blade cutting-off machine designed for cuts at 90°, 45° left and right and intermediate angles.

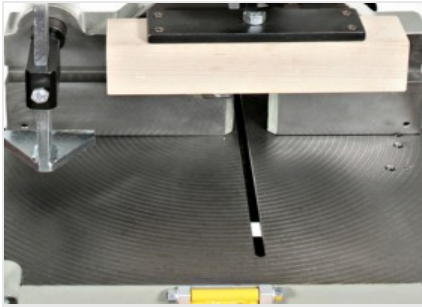

Cutting zone

The sturdy cast-iron horizontal support surface, with its vertical square rigidly coupled to it, forms the workpiece clamping area, which features a large bearing area for optimum clamping of workpieces.

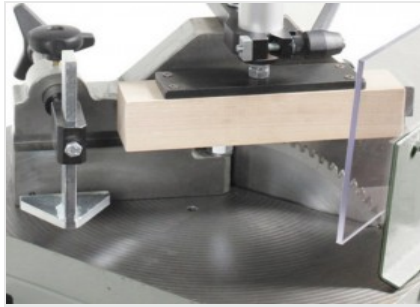

Blade

The cutting-off machine is equipped with a 300-mm cemented carbide blade mounted on a manually actuated feed system.



Vices

The machine is equipped with a horizontal and vertical vice assembly, which are pneumatically actuated in the S version, and manually actuated in the M version.





M-S 300 / SINGLE HEAD CUTTING-OFF MACHINES

BLADE

Made of Widia (mm)

Ø = 300

BLADE FEED

Manual

CUTTING DIAGRAM

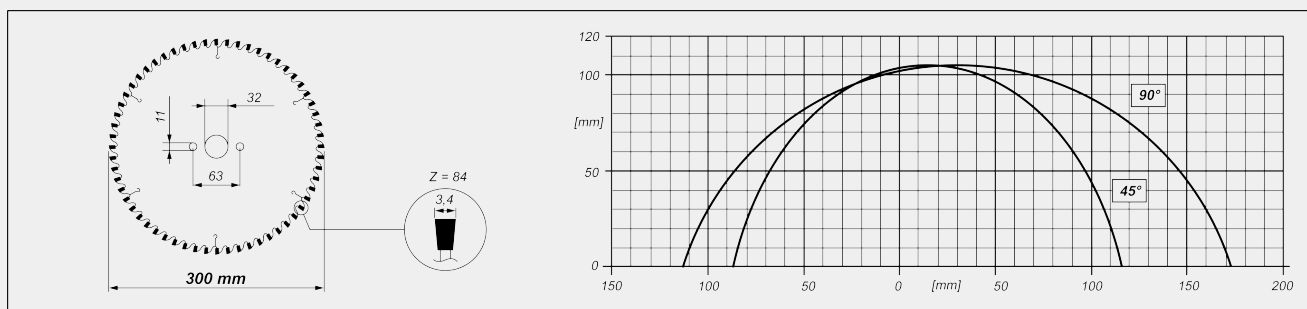

CUTTING UNIT TILTING

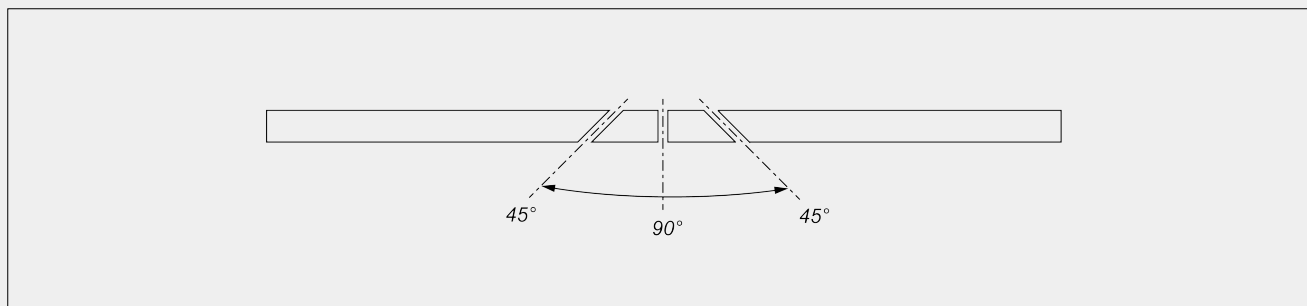

Mechanical adjustment of intermediate angles

CUTTING AREA PROTECTION

Local, manually controlled

LUBRICATION SYSTEM

Manual

Emmegi S.p.A.
 Via Archimede, 10
 41019 - Limidi di Soliera (MO)
 ITALY

Tel +39 059 895411
 Fax +39 059 566286
 P.Iva/C.Fisc 01978870366
 info@emmegi.com
 www.emmegi.com

The right to make technical alterations is reserved.

**PROFILE POSITIONING**

Manual workpiece reference stop ●

WORKPIECE LOCKING

Manual or pneumatic vertical vice (according to model)

1

Horizontal manual vice

1

**MOTOR**

Three-phase brake motor	<input checked="" type="radio"/>
Brake intervention time (s)	10
Power (kW)	1,5

Included Available