



Phantomatic X6

CNC machining centres



Machining centre CNC with 4 controlled axes, used for the working of bars of aluminium, PVC, light alloys in general and steel pieces up to 2 mm. Automatically positioned clamp unit. All models can operate in single piece and multi piece mode, with a single work area for bars up to 7.7 m in length. The PHANTOMATIC X6 and PHANTOMATIC X6 HP models allow machining in pendular mode, with two independent machining areas. The PHANTOMATIC X6 HP version, with 2 supplementary axes to position the clamps and the reference stops allows operation in dynamic pendular mode, carrying out clamps positioning while the machine is working. All CNC axes are absolute and do not require resetting upon machine restart. It has an 8 place tools storage, on the on X axis truck, with the possibility of hosting an angular units and one milling disc, to perform machining on the 5 sides of the piece. The 4th NC axis allows the electrospindle to rotate from 0° to 180° and position itself at any intermediate angle. The machine can therefore perform machining operations on the top and side faces of the profile at any angle within the range.

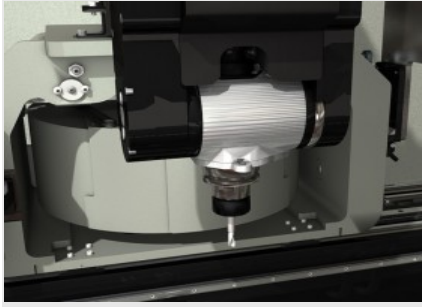

4 axes electric head -X-

7 kW S1 high torque electrospindle allows heavy duty machining. The electrospindle movement along A axis performs 0° to 180° rotation, allowing to work on 3 sides of the profile with no need to reposition it.



Operator interface

The new control version with suspended interface allows the operator to look at the monitor from any position, as it can be rotated around the vertical axis. The operator interface has a 15" touch screen display with all USB connections necessary to interface with a remote PC and NC. It has a push-button panel, mouse and keyboard. It is also set up for the connection of a barcode reader and remote push-button panel. It is equipped with a front USB socket for data transfer.

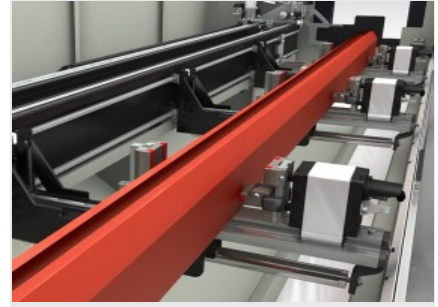

Vices

The machine software can calculate the correct positioning measure for each vice unit, according to the length of the workpiece and to the type of machining to be performed. The automatic positioning system allows picking all vice units and moving them by means of the gantry. This operation is performed at the highest speed and with great precision and spares longer time and collision risks, so that the machine can also be easily used by less experienced operators.

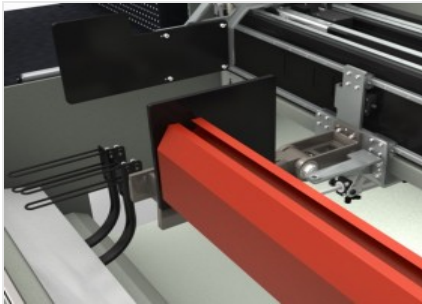

Pneumatic stops

The machine is equipped with strong stops allowing bar reference. One is positioned on the left side (standard) and the other on the right side (optional). Each stop is activated by a pneumatic cylinder, it is retractable type and is automatically selected by the machine software according to the machining to be performed.

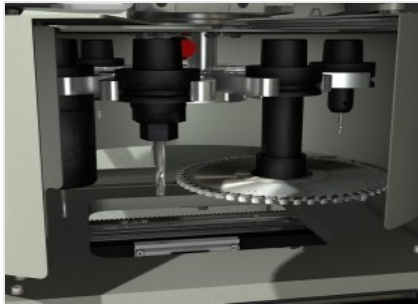

Tool magazine

The tool magazine is integrated on the X axis, in the lower part and behind the electrospindle. It allows great reduction of tool change times. This function is particularly useful in the extrusion head and tail machining, avoiding the stroke to get to the magazine, as it moves simultaneously with the electrospindle and its positions.



Double operation mode

New work system that allows reducing machine stand-still times to a minimum during the loading and unloading of the workpieces. The system allows loading and consequent machining of workpieces, with different lengths, codes and types of machining for the two working areas. This is a very advantageous solution for the field of window/door frames and for small work orders, where machining is required for small lots of different workpieces.





PHANTOMATIC X6 / CNC MACHINING CENTRES

LAYOUT

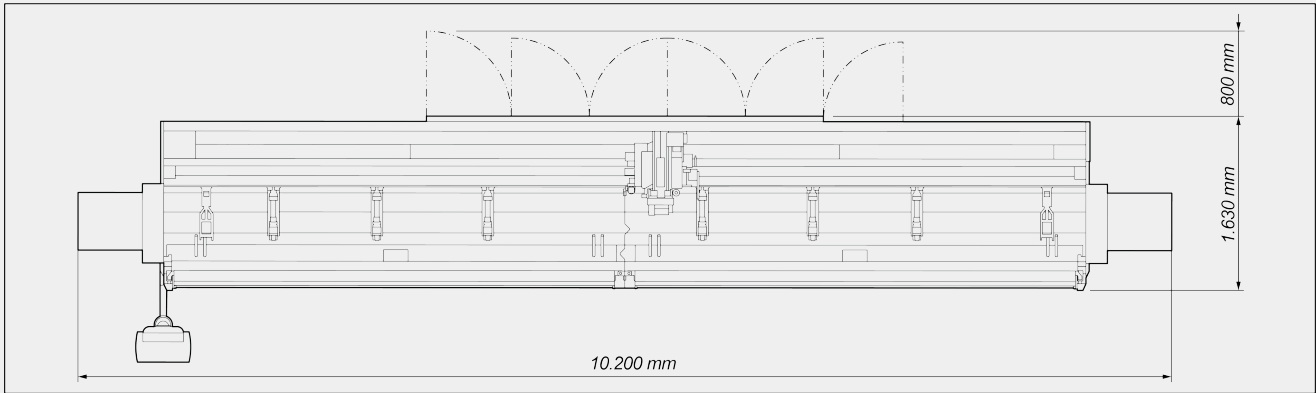

The overall dimensions may vary depending on the product configuration.

AXIS STROKES

X AXIS (longitudinal) (mm)	7.700
Y AXIS (transversal) (mm)	270
Z AXIS (vertical) (mm)	420
A AXIS (electrospindle rotation)	0° ÷ 180°
H AXIS (vice position.) (PHANTOMATIC X6 HP) (mm)	3.300
P AXIS (vice position.) (PHANTOMATIC X6 HP) (mm)	3.300

ELECTROSPINDLE

Maximum power in S1 (kW)	7
Maximum speed (rpm)	16.500
Toolholder cone	HSK - 50F
Automatic tool holder coupling	●
Cooling with heat exchanger	●

AUTOMATIC TOOL MAGAZINE ON BOARD THE GANTRY

Maximum number of magazine tools	8
Maximum number angle machining units that can be inserted in the tool magazine	1
Maximum diameter of the blade that can be inserted in the magazine (mm)	Ø = 180



FUNCTIONS

Multi-workpiece operation (PHANTOMATIC X6 M)	●
Double operation (PHANTOMATIC X6)	●
Dynamic double operation (PHANTOMATIC X6 HP)	●
Extended machining, up to twice the maximum nominal length in X	○
Basic multi-step machining - up to 5 steps	●
Multi-piece mode machining in Y	○
Automatic management of multi-step mode machining(only double operation versions)	○
Workpiece rotation for machining on 4 sides	○

WORKABLE SIDES

With direct tool (upper face and side faces)	3
With angle machining head (heads)	2
With blade tool (upper face, side faces and heads)	1 + 2 + 2

WORK AREA

1F = 1 face machining

5F = 5 faces machining

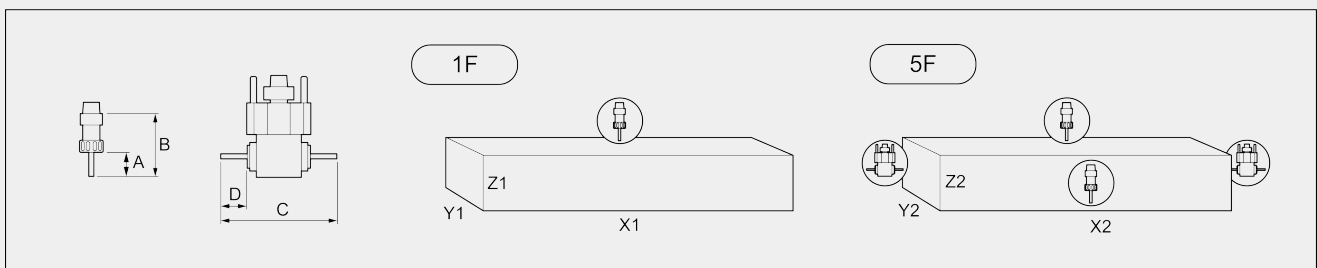

		A	B	C	D	X1	Y1	Z1	X2	Y2	Z2
PHANTOMATIC X6 M	single mode	45	102	232	45,5	7.700	210	250	7.460	180	250
PHANTOMATIC X6	single mode	45	102	232	45,5	7.700	210	250	7.460	180	250
	double mode	45	102	232	45,5	3.220	210	250	2.980	180	250
PHANTOMATIC X6 HP	single mode	45	102	232	45,5	7.320	210	250	7.080	180	250
	double mode	45	102	232	45,5	3.000	210	250	2.760	180	250

Dimensions in mm

TAPPING CAPACITY (with Tap On Aluminium And Through Hole)

With compensator	M8
Stiff (optional)	M10

**PROFILE POSITIONING**

Workpiece reference stops with pneumatic movement	2
Automatic positioning stops through H and P independent axes (PHANTOMATIC X6 HP)	2

WORKPIECE LOCKING

Standard number of pneumatic vices (PHANTOMATIC X6 M - PHANTOMATIC X6)	6
Standard number of pneumatic vices (PHANTOMATIC X6 HP)	8
Maximum number of pneumatic vices (PHANTOMATIC X6 M)	8
Maximum number of pneumatic vices (PHANTOMATIC X6 - PHANTOMATIC X6 HP)	12

SAFETY DEVICES AND PROTECTIONS

Machine integral protection booth	<input checked="" type="radio"/>
Side tunnels	<input type="radio"/>

Included ● Available ○