



Precision T2 E- HS

Double-head cutting-off
machines



Double-head cutting-off machine with 5 controlled axes for aluminium, PVC and light alloys with automatic movement of the mobile head and electronic management of all 45° (internal) to 15° (external) angles, with a precision, within each degree, of 280 positions. In the basic version blade advancement is driven by a couple of hydro-pneumatic cylinders. In version E this advancement is also managed by a couple of CN axes, to ensure optimal speed regulation and output travel of the blades. 550mm-blade Available with a useful cut of 5 m or 6 m in length. The HS (High Speed) version envisions an X axis with higher speed and all necessary protections for the automatic work, even unattended, in order to obtain maximum production.



Control

The ergonomic state-of-the-art control panel features a 10.4" touchscreen display and fully customised software and is packed with functions developed in the Microsoft Windows® environment specifically for this machine. The machining cycle can be optimised by creating cutting lists, thereby reducing scrap and cycle times for workpieces loading-unloading.



Load and unload

The Precision cutting-off machine can be equipped with a roller conveyor on the mobile head, for standard feeding and unloading, or on the fixed head for feeding from the left-hand side. A pneumatic stop device on the mobile head is available to ease positioning of the profile in this loading mode.



Cutting units inclination virtual axis

Inclination of each head of up to 15° outwards is provided by two circular guides mounted on four pairs of steel rollers. This patented solution makes it possible to eliminate obstructions in the cutting area, all to the benefit of profile positioning and clamping, while also offering greater rigidity than traditional systems.



Profile clamping

Making use of the ample space provided by the use of the virtual axis, clamping of the profile to be cut is performed by two horizontal hold-down devices with extreme precision and in absolute safety. For vertical clamping, particularly for special cuts, the machine can be equipped with a patented system of horizontal hold-down devices.



HS - High Speed

The HS - High Speed version is equipped with a faster X axis (mobile head positioning), and features an integral protection on the sides and at the back, to operate in complete safety, increasing productivity. The safety characteristics of this version, fully inaccessible during operation, allow using automatic cutting cycles, even not supervised, at maximum operational performance.



Label printer (Optional)

The industrial label printer allows each cut profile to be identified with identifying features from the cutting list. In addition, barcode printing enables easy identification of the profile itself, which is particularly useful for subsequent machining steps on Machining Centres or assisted assembly lines.





PRECISION T2 E-HS / DOUBLE-HEAD CUTTING-OFF MACHINES

LAYOUT

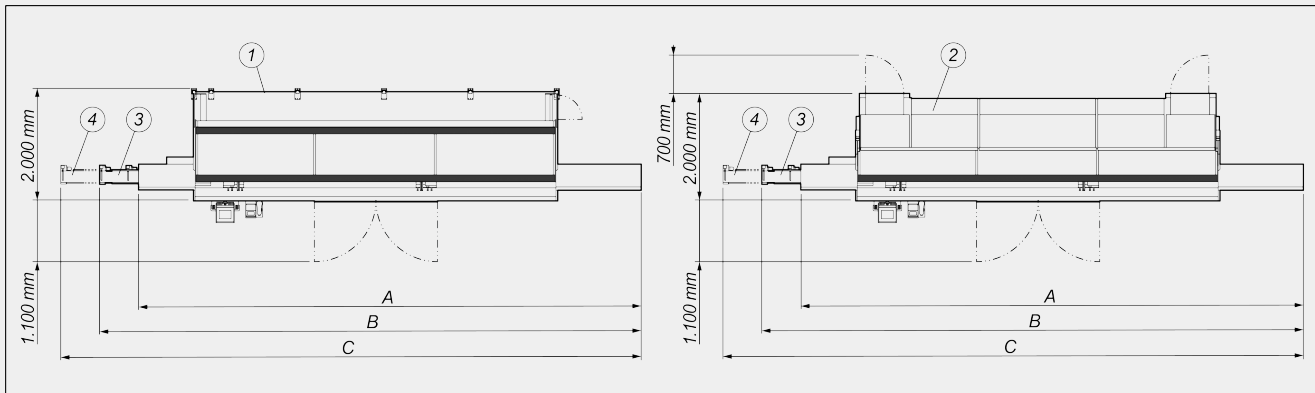

	A	B	C
Precision T2E HS - 5m (mm)	9.100	9.700	10.300
Precision T2E HS - 6m (mm)	10.100	10.700	11.300

1. Enclosure guard of the 4th side (optional)
2. Soundproofed integral protection cabin with internal lighting (optional)
3. Conveyor belt for step-by-step or automatic cut L=1.900 mm (optional)
4. Conveyor belt for step-by-step or automatic cut L=2.500 mm (optional)

The overall dimensions may vary depending on the product configuration.

MACHINE CHARACTERISTICS

Electronic control of the X axis	●
HS version X axis positioning speed (standard) (m/min)	35
Detection of cutting unit tilting through direct measurement system with absolute magnetic strip	●
Mobile head position reading with absolute magnetic strip direct measuring system	●
HS version X axis positioning speed (optional) (m/min)	50
Electronic control of intermediate angles	●
Maximum internal inclination	45°
Maximum external inclination	15°
Hydropneumatic blade feed	●
CN electronic axis of the blade feed (E version)	●
Effective cut, according to model (mm)	5.000 / 6.000
Cemented carbide blade	2
Blade diameter (mm)	550
Blade motor power (kW)	2,64
Electronic profile thickness gauge	○



CUTTING DIAGRAM

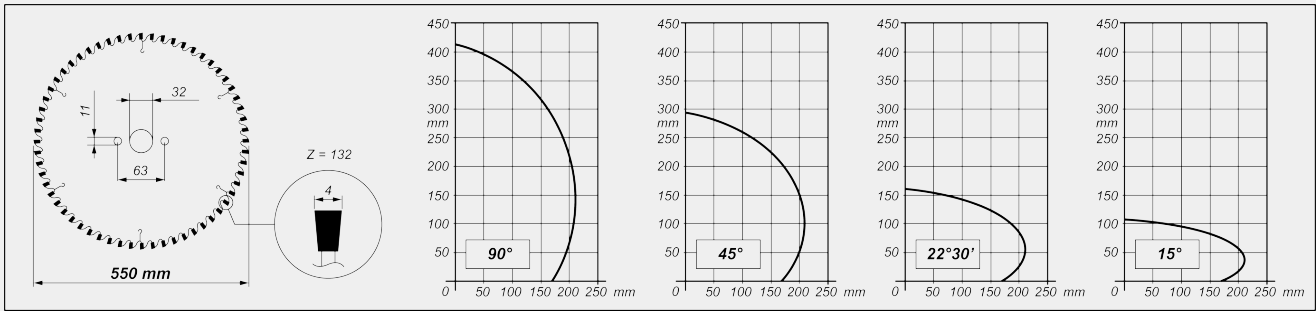

CUTTING UNIT TILTING

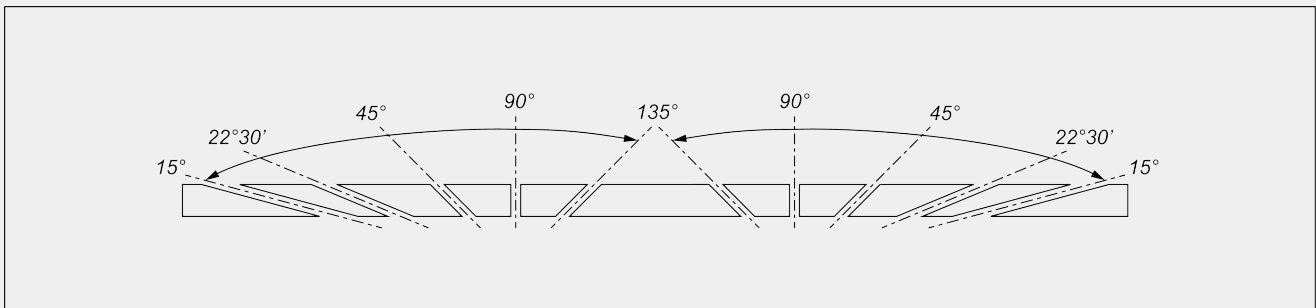

Electronic adjustment of intermediate angles

SAFETY DEVICES AND PROTECTIONS

- Electrically operated fully enclosed front guarding
- Side protection tunnels and wall connection RH and LH fence
- Enclosure guard of the 4th (rear) side
- Soundproofed integral protection cabin with internal lighting

**PROFILE POSITIONING AND CLAMPING**

Pair of horizontal pneumatic vices with "low pressure" device	<input checked="" type="radio"/>
Pair of horizontal vertical vices	<input type="radio"/>
Pair of additional horizontal vices	<input type="radio"/>
Intermediate pneumatic profile support	<input checked="" type="radio"/>
Roller conveyor on the mobile head with servo-controlled pneumatically operated profile supports	<input checked="" type="radio"/>
Additional vice for profile support on mobile head roller conveyor	<input type="radio"/>
Conveyor belt for step-by-step or automatic cut (HS version only)	<input type="radio"/>

FUNCTIONS

Perform single cuts	<input checked="" type="radio"/>
Execution of intermediate angles cuts	<input checked="" type="radio"/>
Execution of cyclical cuts from cutting lists	<input checked="" type="radio"/>
Bar optimisation	<input checked="" type="radio"/>

Included ● Available ○